

## Convection Oven Gas Convection Oven, 10 GN1/1

ITEM # \_\_\_\_\_

MODEL # \_\_\_\_\_

NAME # \_\_\_\_\_

SIS # \_\_\_\_\_

AIA # \_\_\_\_\_



240473 (ZFCG11CSAS)

Convection oven crosswise,  
10x1/1GN, gas

### Short Form Specification

#### Item No. \_\_\_\_\_

Convection oven with direct steam. Main structure in stainless steel. Cooking chamber with side lighting and drip tray. Double glass door. Heating via atmospheric burners with flame failure device. Main burner with pilot light and piezoelectric ignition. Electromechanical thermostat; temperature adjustable from 30°C to 300°C. Timer from 0 to 120 minutes with acoustic alarm. 5-level humidity control.

Supplied with n. 1 "cross-wise" tray rack composed by 2 side hangers, 60 mm pitch, for 10x1/1GN grids.

### Main Features

- Main switch/Cooking mode selector which can be used to set: ON/OFF, hot air without humidification and hot air with humidification (choice of 5 different humidity levels).
- Rapid cooling of oven cavity.
- Timer to set the cooking time, adjustable up to 120 minutes or for continuous operation with an acoustic alarm to show the cycle has finished. At the end of the set cooking time the heat and the fan are automatically switched off.
- Maximum temperature of 300°C.
- Perfect evenness: guarantees perfect distribution of heat throughout the oven cavity.
- Halogen lighting and "crosswise" pan supports allow clear and unobstructed view of the products being cooked.
- Food temperature probe (available as accessory).
- Drip tray to collect residual cooking juices and fat.
- Drip tray under the door to collect condensed liquid available as accessory.
- Capacity: 10 GN 1/1 trays.

### Construction

- Robust structure thanks to stainless steel construction.
- Cooking chamber in 430 AISI stainless steel.
- Double thermo-glazed door with open frame construction, for cool outside door panel. Swing hinged easy-release inner glass on door for easy cleaning.
- Ergonomic door handle.
- Integrated drain outlet.
- 1 pair of 60 mm pitch runners is supplied as standard.
- IPx4 water protection.

APPROVAL: \_\_\_\_\_

## Included Accessories

- 1 of 60mm pitch side hangers for 10 1/1 GN electric oven PNC 922121

- Aluminum grill, GN 1/1 PNC 925004
- Frying pan for 8 eggs, pancakes, hamburgers, GN 1/1 PNC 925005

## Optional Accessories

- Pair of AISI 304 stainless steel grids, GN 1/1 PNC 921101
- Pair of 1/2 GN pan support shelves PNC 921106
- Fat filter for gas 10 and 20 1/1 and 2/1 GN ovens (2 filters are necessary for 20-grid ovens) PNC 921700
- Flue condenser for 10 1/1 and 2/1 GN gas ovens PNC 921701
- Probe for 6-10 1/1 GN ovens PNC 921702
- 1/1 GN drain pan guide kit PNC 921713
- Pair of AISI 304 stainless steel grids, GN 1/1 PNC 922017
- Pair of grids for whole chicken (8 per grid - 1,2kg each), GN 1/1 PNC 922036
- AISI 304 stainless steel grid, GN 1/1 PNC 922062
- Open base for 10 GN 1/1 convection oven PNC 922102
- Shelf guides for 10 1/1 GN oven base PNC 922106
- Cupboard base for 10 GN 1/1 convection oven PNC 922109
- Open base on castors for 10 GN 1/1 convection oven PNC 922114
- 80mm pitch side hangers for 10 1/1 GN gas oven PNC 922116
- 60mm pitch side hangers for 10 1/1 GN gas oven PNC 922122
- Feet for convection ovens 10 GN1/1 & 10 GN2/1 PNC 922127
- Trolley for 10 2/1 GN roll-in rack PNC 922128
- Trolley for 10 1/1 GN roll-in rack PNC 922130
- Retractable hose reel water spray unit PNC 922170
- External side spray unit (needs to be mounted outside and includes support to be mounted on the oven) PNC 922171
- Fat filter for 10 1/1 and 2/1 GN combi steamers (gas and electric) and convection ovens (electric) PNC 922178
- Kit to convert to 10 1/1 GN roll-in rack PNC 922201
- Pair of frying baskets PNC 922239
- Grid for whole chicken (8 per grid - 1,2kg each), GN 1/1 PNC 922266
- Kit universal skewer rack and 6 short skewers for Lengthwise GN 2/1 and Crosswise ovens PNC 922325
- Universal skewer rack PNC 922326
- 6 short skewers PNC 922328
- Smoker for lengthwise and crosswise oven PNC 922338
- Drip tray for convection oven 10 GN1/1 & 2/1 PNC 922431
- Mesh grilling grid, GN 1/1 PNC 922713
- Non-stick universal pan, GN 1/1, H=20mm PNC 925000
- Non-stick universal pan, GN 1/1, H=40mm PNC 925001
- Non-stick universal pan, GN 1/1, H=60mm PNC 925002
- Double-face griddle, one side ribbed and one side smooth, GN 1/1 PNC 925003

**Front**

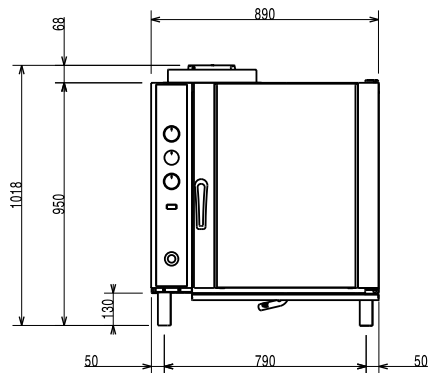

**Side**

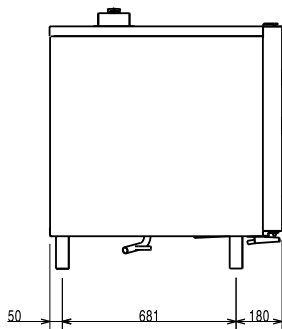

- CW11** = Cold Water inlet 1 (cleaning)
- CW12** = Cold Water Inlet 2 (steam generator)
- D** = Drain
- EI** = Electrical inlet (power)
- G** = Gas connection

**Top**

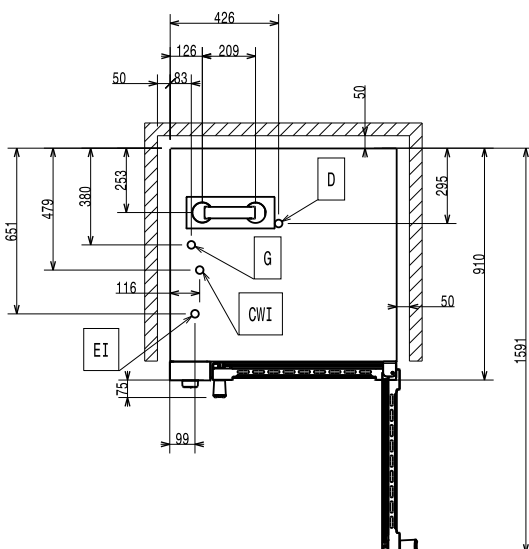

**Electric**

Supply voltage:	220-230 V/1 ph/50 Hz
Auxiliary:	0.35 kW
Electrical power max.:	0.35 kW

**Gas**

Gas Power:	18.5 kW
------------	---------

**Capacity:**

Trays type:	10 - 1/1 Gastronorm
Shelf capacity:	10 Grids

**Key Information:**

External dimensions, Width:	890 mm
External dimensions, Depth:	900 mm
External dimensions, Height:	970 mm
Net weight:	136 kg
Functional level:	Basic
Runners pitch:	60 mm
Cooking cycles - air-convection:	300 °C
Internal dimensions, Width:	590 mm
Internal dimensions, Depth:	479 mm
Internal dimensions, Height:	680 mm