

Convection Oven Electric Convection Oven, 10 GN1/1

ITEM # _____

MODEL # _____

NAME # _____

SIS # _____

AIA # _____



240206 (FCF101E)

10 1/1 GN grids, electric

Short Form Specification

Item No. _____

Main structure in stainless steel. Cooking chamber, grid supports, diffusers, and fan walls in stainless steel. Double glazed door with tempered glass and press-button opening and closing system. Oven chamber with rounded corners and side lighting. Flow Channel ventilation system. Heating via "Incoloy" armoured elements positioned on the convector unit. Electromechanical thermostat; temperature adjustable from 30°C to 300°C; visual display. Timer from 0 to 120 minutes with acoustic alarm. 5-level humidity control. Functional level: base, manual. The pan rack (composed by 2 side hangers) can accommodate n. 10x1/1GN grids and can be converted into a roll-in rack by using an optional kit.

Supplied with n. 1 pan rack, 60mm pitch.

Main Features

- IPx4 water protection.
- Racks can be easily removed without the need for special tools.
- Maximum temperature of 300°C.
- Food temperature probe available as accessory.
- Rapid cooling of oven cavity.
- Halogen lighting and "crosswise" pan supports allow clear and unobstructed view of the products being cooked.
- 5 Stage humidification control, to ensure perfect pastries and succulent roasts.
- Meets the requirements of CE, VDE and DVGW for safety.
- Perfect evenness: guarantees perfect distribution of heat throughout the oven cavity.

Construction

- Access to all components from the front.
- Stainless steel oven cavity with rounded corners.
- Double-glazed door with tempered glass.
- External access door for electrical connections.
- All connections made on the left side below the oven.
- Integrated drain outlet.

APPROVAL: _____

Included Accessories

- 1 of 60mm pitch side hangers for 10 1/1 GN electric oven PNC 922121

Optional Accessories

- Pair of 1/1 GN grids in 304 AISI PNC 921101
- Pair of 1/2 GN pan support shelves PNC 921106
- Water softener with salt for ovens with automatic regeneration of resin PNC 921305
- Probe for 6-10 1/1 GN ovens PNC 921702
- 1/1 GN drain pan guide kit PNC 921713
- Hot base cupboard on castors for 10 1/1 GN oven PNC 922023
- Pair of grids for whole chicken (8 per grid - 1,2kg each), GN 1/1 PNC 922036
- Base for 10 1/1 GN oven PNC 922102
- Shelf guides for 10 1/1 GN oven base PNC 922106
- Hot base cupboard for 10 1/1 GN oven PNC 922112
- Base on castors for 10 1/1 GN oven PNC 922114
- 80mm pitch side hangers for 10 1/1 GN electric oven PNC 922115
- 60mm pitch side hangers for 10 1/1 GN electric oven PNC 922121
- Feet for 6&10x1/1 GN and 10x2/1 GN ovens PNC 922127
- Trolley for 10 1/1 GN roll-in rack PNC 922130
- Retractable hose reel water spray unit PNC 922170
- External side spray unit (needs to be mounted outside and includes support to be mounted on the oven) PNC 922171
- Kit to convert to 10 1/1 GN roll-in rack PNC 922201
- Grid for whole chicken (8 per grid - 1,2kg each), GN 1/1 PNC 922266
- Kit universal skewer rack and 6 short skewers for Lengthwise GN 2/1 and Crosswise ovens PNC 922325
- Universal skewer rack PNC 922326
- Smoker for lengthwise and crosswise oven PNC 922338

Front

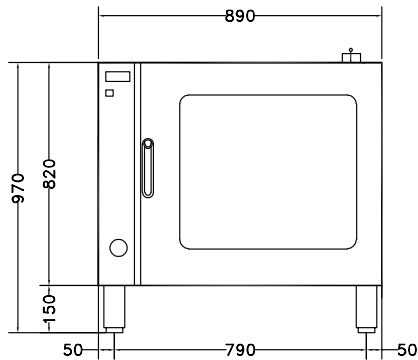

Side

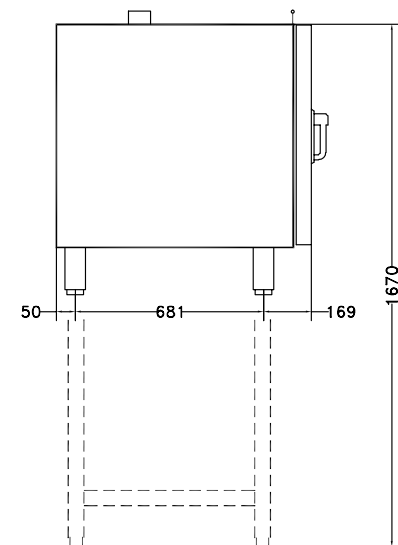

- CW11** = Cold Water inlet 1 (cleaning)
- CW12** = Cold Water Inlet 2 (steam generator)
- D** = Drain
- EI** = Electrical inlet (power)

Top

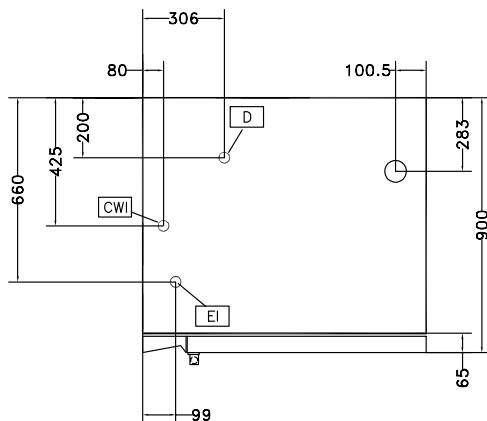

Electric

| | |
|-------------------------------|-----------------------|
| Supply voltage: | |
| 240206 (FCF101E) | 380-400 V/3N ph/50 Hz |
| Auxiliary: | 0.3 kW |
| Electrical power max.: | 17.3 kW |

Capacity:

| | |
|------------------------|----|
| Shelf capacity: | 10 |
|------------------------|----|

Key Information:

| | |
|---|----------------|
| External dimensions, Width: | 890 mm |
| External dimensions, Depth: | 900 mm |
| External dimensions, Height: | 970 mm |
| Net weight: | 121.2 kg |
| Functional level: | Basic |
| Type of grids: | 1/1 Gastronorm |
| Runners pitch: | 60 mm |
| Cooking cycles - air-convection: | 300 °C |
| Internal dimensions, Width: | 590 mm |
| Internal dimensions, Depth: | 503 mm |
| Internal dimensions, Height: | 680 mm |